

**G 250 / G 500 / G 1000**



**G Series**



**G 250/500**



**G 1000**

**Produttori automatici di ghiaccio a scaglie granulari.**

Struttura interna ed esterna interamente in acciaio inox 18/8. Ghiaccio a granuli compatti, per i diversi impieghi in ristoranti, pescherie, self-service ed industrie. Modelli modulari, senza deposito interno di raccolta ghiaccio, occorre abbinarli ad un contenitore di raccolta BIN (disponibile in diversi modelli).

**Automatic granular ice flakers.**

*Inner and outer structure of stainless steel 18/8. Compact granular ice for various different uses in restaurant, fish-shops, self-service and industries. Modular models, without internal ice storage bin. Must be combined with a collection BIN (different models available).*

**Machines à paillettes.**

*Structure intérieur et extérieur en acier inox 18/8. Glace en paillettes granulées pour usages dans les restaurants, les poissonneries, les self-services et l' industries. Modèles modulaires: sans réserve intégrée de glaçons il faut l' assortir d' un réserve BIN (disponibles dans divers modèles).*



# G Series

# G 250-500 / G 1000

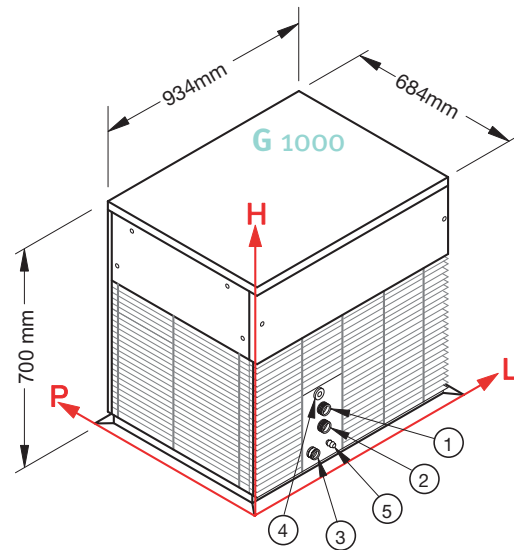
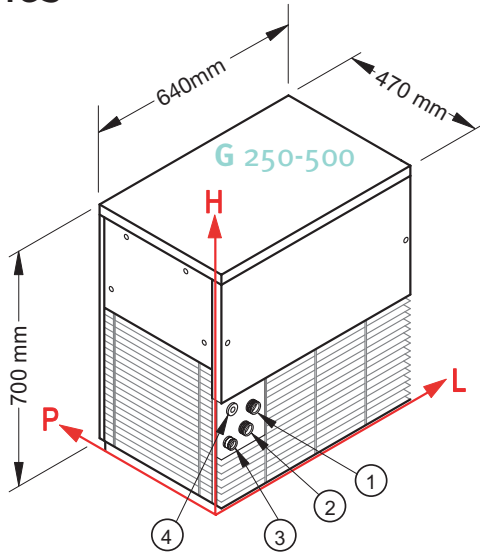

	1			2*			3			4			5*		
	L	H	Ø	L	H	Ø	L	H	Ø	L	H	Ø	L	H	Ø
<b>G 250-500</b>	116	282	3/4"	84	238	3/4"	34	228	24mm	58	292	-	-	-	-
<b>G 1000</b>	372	187	3/4"	372	120	3/4"	337	60	24mm	358	257	-	382	60	12mm

\* Only for water cooling system

	Produzione in 24 h, sino a: Production in 24 h till: Production en 24 h jusqu'à:	Raffreddamento Cooling System Condenseur	Refrigerante Refrigerant Fluide refrigerant	BIN utilizzabile Usable BIN Réserve utilisable	Voltaggio Standard Standard Voltage Tension standard	Potenza assorbita Input power Puissance absorbée	Consumo acqua (l/kg) Water consumption (l/kg) Consommation d'eau (l/kg)	Dimensioni (LxPxH) Sizes (WxDxH) Dimension (LXPXH)	Dimensioni con imballo (LxPxH) Sizes with packing (WxDxH) Dimension (avec emballage) (LXPXH)	Peso netto/lordo Weight net/gross Poids net/brut
<b>G 250</b>					V/Hz	W				
<b>250 Kg</b>	A W	R404A	BIN 240PE - G250/500 BIN T120 - G250/500 BIN T280 - G250/500 Double Roller Bin - G250/500 ROLLER BIN	220-240/1/50	1050 W	A 1 W 5,2	mm 640x470x700	mm 695x540x940	82/93 Kg	
<b>G 500</b>					V/Hz	W				
<b>500 Kg</b>	A W	R404A	BIN 240PE - G250/500 BIN T120 - G250/500 BIN T280 - G250/500 Double Roller Bin - G250/500 ROLLER BIN Double Roller Bin 500	220-240/1/50	1700 W	A 1 W 5,3	mm 640x470x700	mm 695x540x940	104/113 Kg	
<b>G 1000</b>					V/Hz	W				
<b>1000 Kg</b>	A W	R404A	Double Roller Bin 500	400/3N/50	3200 W	A 1 W 5,3	mm 934x684x700	mm 1000x770x920	172/195 Kg	

Finitura: acciaio inox 18/8, scotch brite - Finishing: 18/8 stainless steel, scotch brite - Carrosserie: inox 18/8, scotch brite.



Condizioni  
Conditions  
Conditions



Watt + 43°C (230/1/50)



V / Hz



Minimum	+10 °C	+3 °C	-10%	1bar (14psi)
Maximum	+43 °C	+32 °C	+10%	6bar (84psi)



www.bremaice.it  
info@bremaice.it

VIA DELL'INDUSTRIA, 10

20020 VILLA CORTESE (MI), ITALY

TEL. +39 0331 434811  
FAX +39 0331 433833